

## The Use of the ACQUITY QDa Detector for a Selective, Sensitive, and Robust Quantitative Method for a Potential Genotoxic Impurity

---

Janet Hammond

Waters Corporation

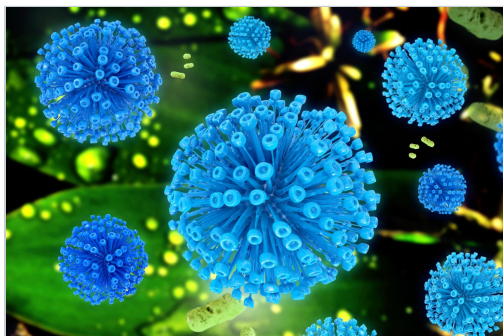

---

## Abstract

In this application note we describe an analytical method for the detection and quantitation of a GTI, 1-phenylpiperazine in an active pharmaceutical ingredient (API) at a limit of quantitation (LOQ) of 0.5 ppm relative to the API. It uses the ACQUITY QDa Detector, which is a small, simple to use robust mass detector and the ACQUITY UPLC H-Class System fitted with an ACQUITY UPLC Column Manager.

## Benefits

- High selective, sensitive, and robust analysis using the ACQUITY QDa Detector
- ACQUITY UPLC H-Class System provides high resolution and throughput with a short analysis time of 3 minutes
- The option of either MassLynx Mass Spectrometry Software or Empower Chromatography Data Software control allows the system to be deployed in many different analytical laboratories
- Facility to divert the LC flow to waste preventing contamination of the source by high concentrations of API

---

## Introduction

Genotoxic impurities (GTI) are compounds that have the potential to modify DNA and as a consequence cause cancer. It is important that drug manufacturers identify the presence of these impurities early in the drug development process, and develop analytical methods that are sensitive and specific enough to determine the levels in both drug substance and drug product.

Maximum allowable levels of GTIs are based on a Threshold for Toxicological Concern (TTC) of 1.5  $\mu$ g per day, corresponding to 1 ppm or lower. This is orders of magnitude lower than for general pharmaceutical impurities analysis which is at the 500 ppm level.

Analytical instrumentation used routinely in pharmaceutical analysis such as liquid chromatography (LC) with ultraviolet (UV) detection for non volatile compounds, or gas chromatography (GC) with flame ionization detection (FID) for volatile compounds are preferred. However, the low levels of detection required for genotoxic impurities present a significant challenge. In these situations, MS detection is required in order to achieve the desired sensitivity, specificity, and robustness. Some of these methods are required to provide support during the whole life cycle of a drug from early development to manufacturing quality control.

Here, we describe an analytical method for the detection and quantitation of a GTI, 1-phenylpiperazine in an active pharmaceutical ingredient (API) at a limit of quantitation (LOQ) of 0.5 ppm relative to the API. It uses the ACQUITY QDa Detector, which is a small, simple to use robust mass detector and the ACQUITY UPLC H-Class System fitted with an ACQUITY UPLC Column Manager.

---

# Experimental

## UPLC method conditions

LC system:	ACQUITY UPLC H-Class with ACQUITY UPLC Column Manager
Column:	ACQUITY UPLC HSS, 1.8 $\mu\text{m}$ , 2.1 x 50 cm
Column temp.:	40 °C
Sample temp.:	10 °C
Injection vol.:	1 $\mu\text{L}$
Flow rate:	0.5 mL/min
Mobile phase A:	0.05% formic acid in water
Mobile phase B:	0.05% formic acid in acetonitrile
Gradient:	5 to 95% B at 1.5 min held until 2.1 min then 5% B
Run time:	3 minutes

## MS conditions

### MS conditions

MS system: ACQUITY QDa Detector

Ionization mode: ESI positive

Single ion recording  
(SIR):  $m/z$  163.1 Da [M+H]<sup>+</sup>

Capillary voltage: 0.8 kV

Sampling frequency: 5 Hz

Probe temp.: 600 °C

Cone voltage: 10V

### Data management

MassLynx Software v4.1

### Sample preparation

10, 5, 1, 0.5, and 0.1 ppm standards of 1-phenylpiperazine (with respect to 1 mg/mL API) were prepared in 10% acetonitrile: 90% water.

---

## Results and Discussion

The structure of 1-phenylpiperazine is shown in Figure 1. It has a nominal molecular weight of 162 Da. Full scan analysis of 1-phenylpiperazine on the ACQUITY QDa Detector detected the expected  $[M+H]^+$  ion at 163.1 Da.

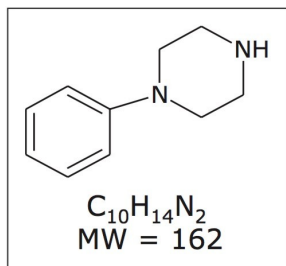

*Figure 1. Structure of 1-phenylpiperazine.*

### Reconfiguration of the ACQUITY UPLC Column Manager

In order to avoid contamination issues and poor recoveries during trace analysis involving MS, it is preferable where possible to exclude the matrix and API from entering the MS source. Reconfiguring the ACQUITY UPLC Column Manager is one of the available options which allows flow to be diverted away from the ACQUITY QDa Detector. The ACQUITY UPLC Column Manager tubing configuration on the ACQUITY UPLC H-Class System facilitates the diversion of the solvent flow to waste by timed events using the instrument control software method events table. As shown in Figure 2, the outlet of the ACQUITY UPLC Sample Manager (FL or FTN) connects directly to the active column pre heater of the column that is being used for the experiment. The outlet of the column connects to the centre of the outlet switching valve (OSV). The 'W' port on the OSV (position 1) connects to waste. The '1' port on the OSV (position 2) is connected to the detector. Using the instrument control software method events table during the run, the column manager is used to move the OSV between positions 1 (waste) and 2 (detector) at the desired time intervals.

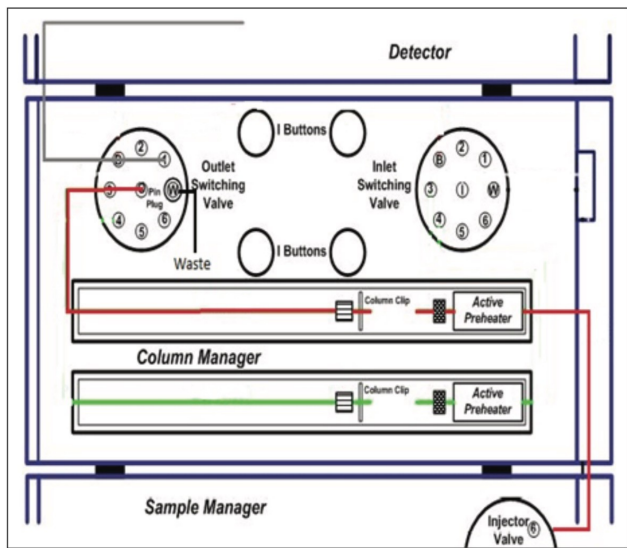

Figure 2. Configuration of the ACQUITY UPLC Column Manager to facilitate the diversion of the solvent flow to waste.

## Method development

The UPLC method was optimised to ensure that 1-phenylpiperazine eluted before the API. The final method resulted in an elution time for 1-phenylpiperazine of 1.2 min and of 1.5 min for the API. An event time of 1.3 min was used to divert the API to waste as seen in Figure 3.

ACQUITY QDa Detector probe temperature and cone voltage conditions were optimised for maximum sensitivity for the 1-phenylpiperazine standards.

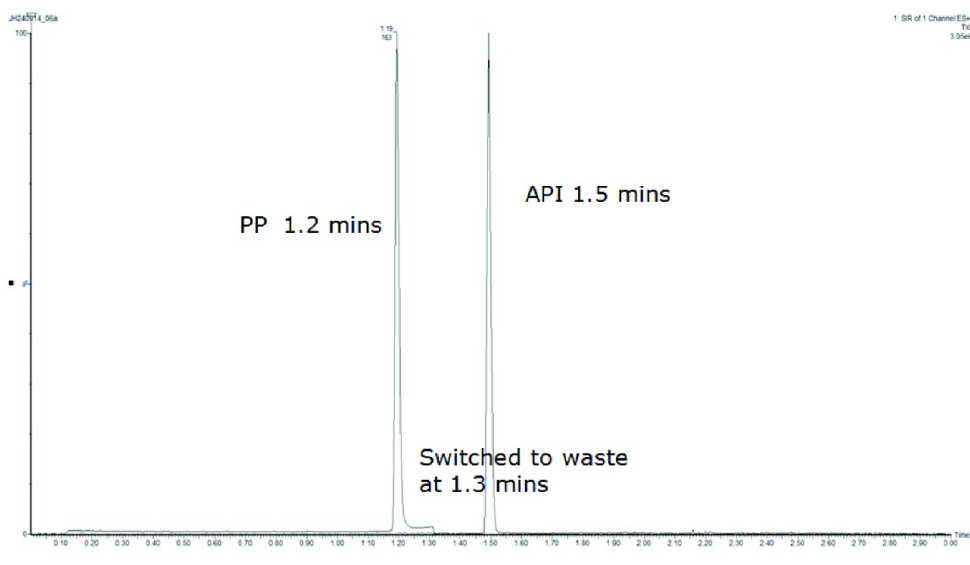

Figure 3. SIR traces for  $MH^+$  from both 1-phenylpiperazine and the API.

## Matrix effects

Selectivity issues can arise during these very low levels of analysis because the target analyte (GTI) is at very low levels in the presence of a large concentration of API, a counter-ion or in the case of drug products, excipients. It is important when carrying out these types of analyses that a series of samples of API or drug product spiked with the corresponding GTI are also analysed. This will indicate if there are any issues relating to stability, ion suppression, or enhancement effects. In this analysis, samples were prepared by spiking into the API at 0.1, 0.5, and 10 ppm of 1-phenylpiperazine and analyzed. The result of this experiment showed that the areas of five replicates were 28% lower when compared to the areas of the unspiked standards. This implies the matrix does have an effect on the response of 1-phenylpiperazine. The areas of the 0.5 ppm standard of both spiked and unspiked samples are shown in Figure 4.

Sample number	Area	Sample number	Area
1	802	1	1152
2	791	2	1182
3	847	3	1142
4	827	4	1139
5	810	5	1162
A		B	

*Figure 4. A) Areas from 5 injections of 0.5 ppm std of 1-phenylpiperazine spiked into the API. B) Areas from 5 injections of an unspiked 0.5 ppm standard of 1-phenylpiperazine.*

## Linearity

The linearity of the method was evaluated with five standards of 0.1, 0.5, 1.0, 5, and 10 ppm of 1-phenylpiperazine in a 1 mg/mL API solution. The method showed good linear correlation between the peak areas and the ppm concentration (Figure 5). The signal to noise for the LOQ standard is more than 10 to 1 and signal to noise ratio is 3 to 1 at the limit of detection (LOD) standard (Figures 6A and 6B). The percentage standard deviation of the six individual injections of all the five standards was less than 4%.



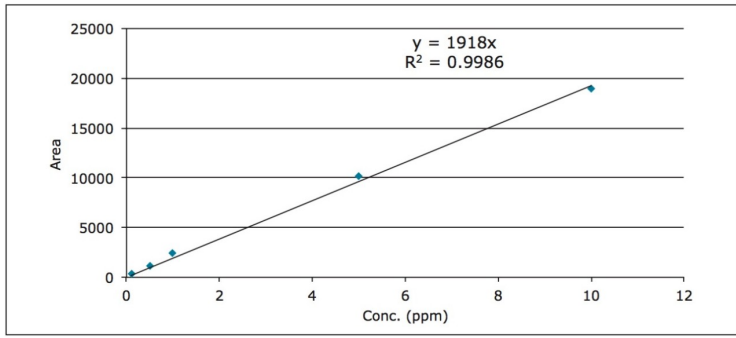

Figure 5. Calibration graph showing the linearity across the 5 1-phenylpiperazine standards.

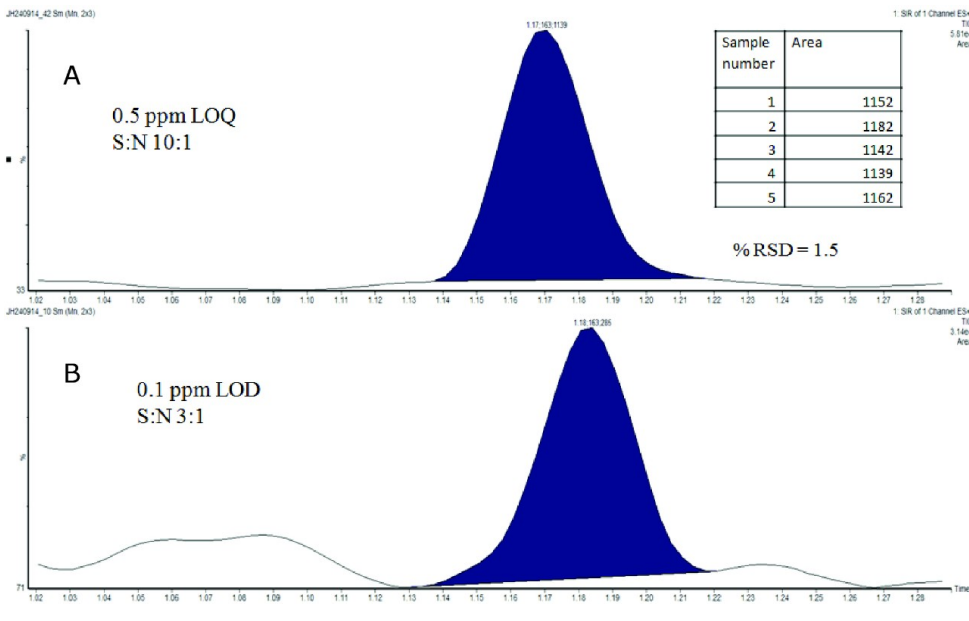

Figure 6. A) SIR trace for the LOQ (0.5 ppm) of the 1-phenylpiperazine standard. B) SIR trace for the LOD (0.1 ppm) 1-phenylpiperazine standard.

## Analysis of the API

Three different batches of a 1 mg/mL solution of the API in 10% acetonitrile: 90% water were analysed and the results showed that all contained less than 0.5 ppm of 1-phenylpiperazine. The result from a typical batch is shown in Figure 7.

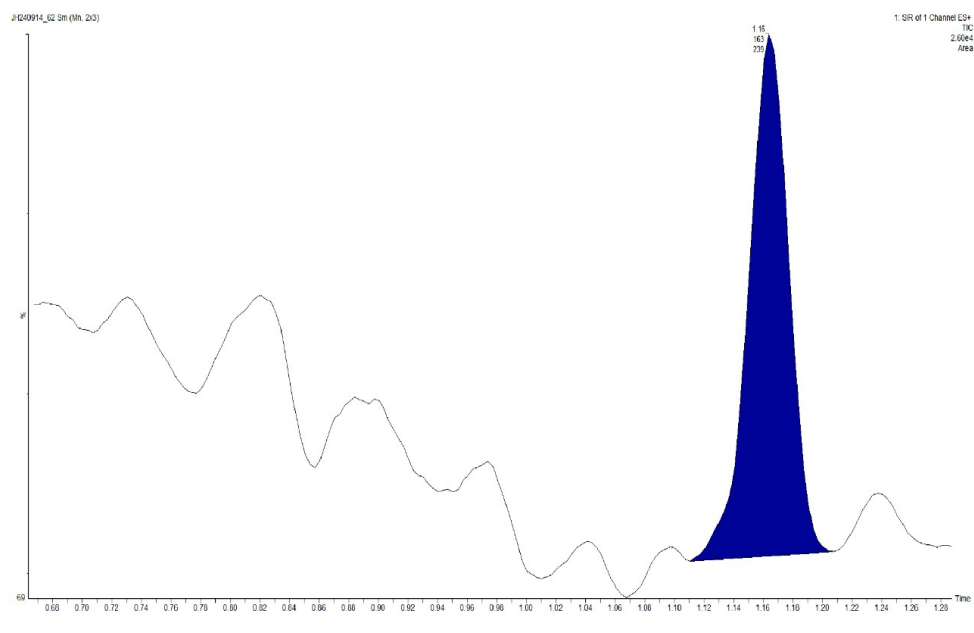

Figure 7. Analysis for 1-phenylpiperazine in a typical batch of API.

---

## Conclusion

The ACQUITY UPLC H-Class System and ACQUITY QDa Detector provide an excellent solution for analysis of 1-phenylpiperazine in the presence of an API.

- The use of the ACQUITY QDa Detector with SIR achieves high specificity and sensitivity to provide a method for analysis of 1-phenylpiperazine down to the LOQ of 0.5 ppm related to 1 mg/mL API in solution.
- UPLC provides high resolution and high throughput, which delivers high efficiency with an analysis time of 3 min.
- ACQUITY UPLC Column Manager allows the facility to switch the solvent flow to waste before the API elutes, preventing contamination of the source.
- Peak area reproducibility showed % RSD for all the 1-phenylpiperazine standards was less than 4%.
- The calibration graph was linear for a set of 1-phenylpiperazine standards from 0.1 to 10ppm.
- The option of either MassLynx or Empower Software control allows the system to be deployed in many different analytical laboratories.
- Can be used throughout all stages of drug development and QC environments

---

## Featured Products

[ACQUITY UPLC H-Class PLUS System](#)

[ACQUITY QDa Mass Detector](#)

[MassLynx Mass Spectrometry Software](#)

[ACQUITY UPLC Column Manager](#)

Available for purchase online

[ACQUITY UPLC HSS C18 Column, 100Å, 1.8 µm, 2.1 mm X 50 mm, 1/pkg](#)

720005372, April 2015