

Application Note

## Routine MS Detection for USP Chromatographic Methods

---

Daniel S. Root, Thomas E. Wheat, Patricia R. McConville

Waters Corporation



---

## Abstract

This application note presents a systematic protocol for using MS detection directly with unmodified USP methods. The USP assay for Irbesartan is used as an example to illustrate the peak transfer protocol.

### Benefits

This approach enables mass spectral analysis of peaks directly from unmodified USP HPLC chromatographic methods.

---

## Introduction

The USP analytical methods monographs are widely used in the development and quality control of drug substances and finished drug products. These methods are typically robust and are suitable for the identification and assay of active pharmaceutical ingredients (APIs) and their related substances and impurities. There are circumstances, however, where alternative analytical methods are necessary.

By far, the more common circumstance revolves around the needs of validation. In order to satisfy the selectivity and specificity criteria common to any methods validation, peak identification and purity are required. In this case, alternative methods are routinely employed to complement the original optical detection methods. Less common, but no less important, is the circumstance of the unexpected peak appearing in a routine analysis. Undoubtedly, this kind of serious event will necessitate a formal investigation within which early steps will focus on the identification of the offending peak. Again, alternative analytical methods must be engaged to achieve this goal.

Mass spectral detection (MS) is the most predominant form of alternative detection. The richness of mass spectral data makes it an obvious first choice. Unfortunately, the majority of USP methods use mobile phases made up of non-volatile buffers, limiting detection to UV or other optical methods. To utilize MS, time-demanding fraction collection, evaporation, and reconstitution then become part of the process. To overcome this problem, numerous protocols have been proposed to convert these chromatographic methods to completely volatile mobile phases, making the methods compatible with mass spectral analysis. This redevelopment can be complicated and costly. Furthermore, it can prove difficult to demonstrate that the original chromatographic selectivity has been perfectly preserved.

The ACQUITY UPLC System with 2D-LC Technology and integrated ACQUITY QDa Mass Detector offers a solution to this challenge. With this system, a peak of interest can be transferred from an unmodified USP HPLC method, trapped, the mobile phase replaced with a volatile MS-friendly mobile phase, and the peak eluted to a mass spectral detector. This application note presents a systematic protocol for using MS detection directly with unmodified USP methods. The USP assay for Irbesartan is used as an example to illustrate the peak transfer protocol.

---

# Experimental

## Method conditions

System: ACQUITY UPLC System with 2D-LC  
Technology

Alpha pump: ACQUITY UPLC H-Class  
Quaternary Solvent Manager (QSM)

Beta pump: ACQUITY UPLC I-Class Binary  
Solvent Manager (BSM)

Dilution pump: ACQUITY Isocratic Solvent  
Manager (ISM)

Sample manager: ACQUITY UPLC H-Class Sample  
Manager – Flow-Through-Needle  
(SM-FTN) Column manager (CM-A)  
configured for two active pre-  
heaters, 2D column tubing kit (p/n  
205000764) and 2D valve kit (p/n  
205000952)

UV detection: ACQUITY UPLC Photodiode Array  
(PDA) Detector 220 nm

Mass detection: ACQUITY QDa Detector

Software: MassLynx 4.1 SCN 888 with Waters  
pump control

Chromatographic parameters

## USP method

HPLC column:	XSelect HSS T3 4.6 x 250 mm 5 $\mu$ m (L1)
Mobile phase:	Buffer solution and acetonitrile (60:40)
Buffer solution:	0.55% Phosphoric acid in water adjusted to pH 3.2 with triethylamine
Flow profile:	Isocratic
Flow rate:	1.0 mL/min
Injection:	10 $\mu$ L

## LC-MS method

UPLC column:	BEH C <sub>18</sub> , 2.1 x 50 mm, 1.7µm
Mobile phases:	Water, acetonitrile
Dilution pump:	0.1% formic acid in water, 0.2 mL/min
Flow profile:	Gradient 0 to 95% Acetonitrile, 3 minutes, 0.5 mL/min
Mass detector:	ACQUITY QDa
Ionization mode:	ESI+, scan
Acquisition range:	Full scan 100 – 500 <i>m/z</i>
SIR functions:	Irbesartan <i>m/z</i> 429.2  Irbesartan related compound A (RC-A) <i>m/z</i> 447

## Sample

Irbesartan and Irbesartan related compound A (RC-A) were purchased from USP (Rockville, MD 20852). Irbesartan sample and standard solutions were prepared as per the USP monograph for Irbesartan.<sup>1</sup>

## The peak transfer protocol

When designing a multi-dimensional protocol, it is useful to begin with a simple bulleted list describing the main tasks and steps of the process. A progression then follows translating the protocol into the actual plumbing and valve events, and finally, transcribing these events into a form that can be entered into the method editor and gradient table of an instrument method. For this peak transfer, the process can be initially described by the following protocol.

- The standard USP method is run with UV detection. In fact, the hallmark of this approach is that the USP HPLC method can be run without any changes or modifications

- When the peak begins to elute from the HPLC column, entered in the method as a timed event, the following steps occur:
  - flow from the PDA is diverted to the UPLC Column
  - flow from the Beta pump is delivered to the HPLC column
  - flow from the Dilution pump mixes with the Beta pump mobile phase diluting the organic composition of the flow entering the UPLC column (at-column dilution) so that the compound does not continue to migrate along the UPLC column
  - flow from the UPLC column is sent to waste
  - The USP mobile phase from the Alpha pump elutes from the HPLC column directly to waste
- The peak is now trapped at the head of the UPLC column
  - The MS-compatible mobile phase from the Beta pump, which is free of any non-volatile additives, flushes the UPLC column, replacing the USP mobile phase
  - Flow through the UPLC column remains diverted to waste until the flushing is complete
- With the original USP mobile phase flushed out by the additive-free Beta pump flow, the flow from the UPLC column is diverted to the ACQUITY QDa Detector
- The compound of interest, still retained on the UPLC column, is then eluted to the ACQUITY QDa Detector with an increasing gradient of acetonitrile
- The ACQUITY QDa Detector then monitors the eluate using a single ion channel for expected compounds and full scan mode to collect full mass spectral information for use in potential unknown identification

To execute these steps in the above protocol, a specific configuration of fluidic connections was made using the two, 2-position, 6-port valves of the ACQUITY UPLC Column Manager. Figures 1 through 4 show the column manager plumbing and describe the key events associated with the steps in the peak transfer process.

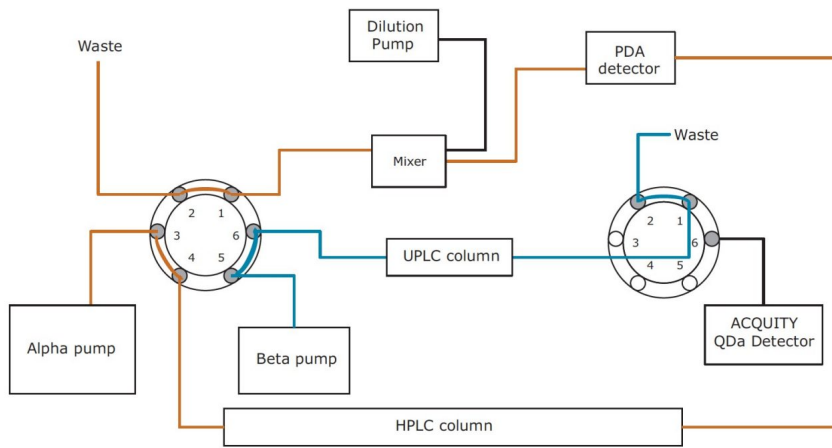

Figure 1. Step 1. The flow from the Alpha pump (USP mobile phase) is directed to the HPLC column. The sample is injected and the USP method is run with UV detection (red flow path). The Beta pump flows through the equilibrated UPLC column (blue path), then out to waste.

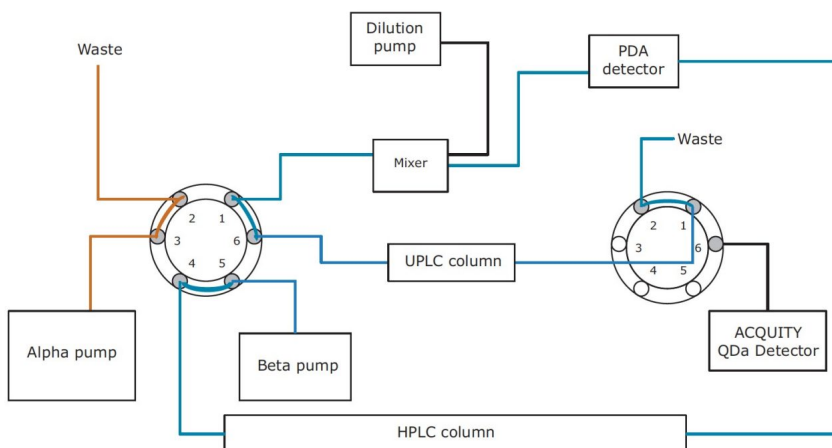
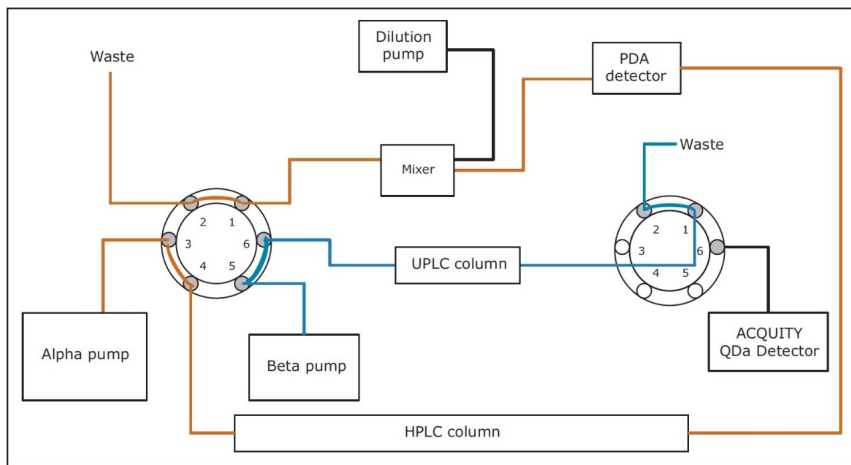
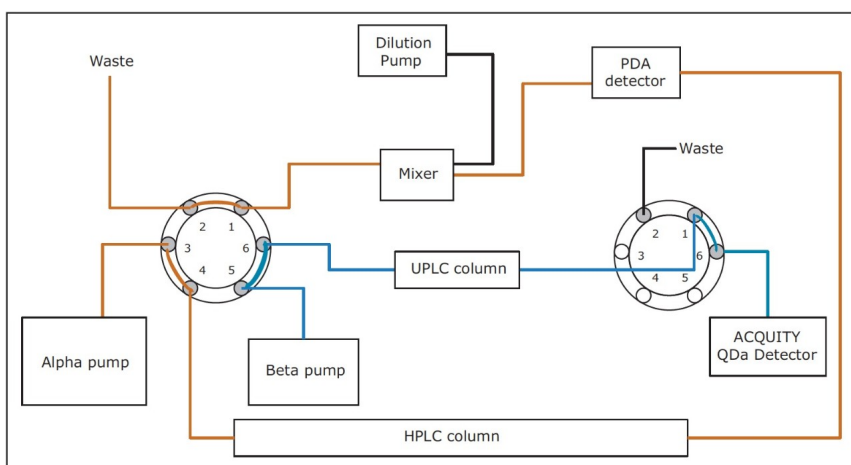

Figure 2. Step 2. When the desired peak begins to elute, a timed event, the left valve turns to position two. The Alpha pump flow is diverted to waste and the flow from the Beta pump is directed through the HPLC column eluting the peak of interest onto the UPLC column (Blue flow path). At the same time, the flow from the dilution pump is combined with that from the HPLC column at a low-volume mixer. The reduced organic composition of the diluted mobile phase facilitates the trapping of the peak of interest on the UPLC column.





*Figure 3. Step 3. With the peak transfer to the UPLC column complete, the left valve returns to position 1 and the HPLC column is now regenerated. The Beta pump flushes the UPLC column to waste with 100% water retaining the analyte.*



*Figure 4. Step 4. With the mobile phase flush of the UPLC column complete, the right valve turns to position two and the peak of interest is eluted to the ACQUITY QDa Detector with a gradient of increasing acetonitrile.*

To complete the protocol all of the described tasks, plumbing, and pump and valve events must be transcribed into the format of an instrument method. An example of a final gradient table with pump parameters and valve events can be seen in Table 1. Individual module parameters have been consolidated into a single table. The time settings marked with an asterisk are the start and stop times for the peak transfer window. In all methods of this type, as the settings for the start and end of the peak transfer window change, so do all subsequent timed events in the method.

Time	QSM (Alpha pump) A: Buffer B: Acetonitrile				BSM (Beta pump) A: Water B: Acetonitrile				ISM (Dilution pump) 0.1% Formic in water		CM-A	
	Flow	A	B	Curve	Flow	A	B	Curve	Flow	A	Left valve	Right valve
0.00	1.00	60	40		0.20	60	40		0.20	100	1	1
12.90*	0.10	60	40	11	0.20	60	40	6	0.20	100	2	1
14.40*	0.10	60	40	6	0.20	60	40	6	0.20	100	1	1
14.41	0.10	60	40	6	0.20	100	0	1	0.20	100	1	1
18.40	0.10	60	40	6	0.50	100	0	6	0.20	100	1	1
18.41	0.10	60	40	6	0.50	100	0	6	0.20	100	1	2
21.40	1.00	60	40	6	0.50	5	95	6	0.20	100	1	2
25.00	1.00	60	40	6	0.20	60	40	1	0.20	100	1	1

*Table 1. An example gradient table with pump parameters and valve events for the peak transfer protocol. The asterisks denote the start and stop time of the peak transfer window.*

## At-column dilution (ACD)

At-column dilution is a technique used to facilitate the injection of large volumes of sample diluent containing high amounts of organic solvent onto reversed-phase columns without compromising the chromatography. Typically, when a large volume of highly organic diluent is injected onto a reversed-phase column, poor analyte retention and chromatographic peak distortions are observed. The magnitude of the distortion will be dependent on the relative organic composition of the sample diluent and the hydrophobicity of the analytes, and can vary from a shift in retention to peak splitting and smearing. During a 'heart-cut,' or peak transfer, a specific volume of the mobile phase, containing the peak of interest, is transferred to a second-dimension column. If that 'cut' contains a high percent of organic, the same poor retention and chromatographic distortions mentioned above can be observed on the second-dimension column. By adding an additional aqueous dilution flow to the injected or 'cut' volume prior to the second-dimension column, the organic composition can be significantly reduced, resulting in improved retention and eliminating possible chromatographic peak distortions. This is the basis of Waters at-column dilution [US Patent (Waters Corporation) – 6,790,361 B2]. A sample diagram of at-column dilution is shown in Figure 5.

When using ACD with a peak transfer, the flow from the dilution pump is set to 100% aqueous and mixes with the eluate from the first dimension column prior to reaching the head of the second-dimension column. The final organic composition of the mobile phase as it flows into the second-dimension column is determined by the proportion of the two flow rates. In this application, the dilution pump flow matched that of the Beta pump during peak transfer. This lowered the organic composition of the mobile phase from 40% acetonitrile in the USP mobile phase to 20% passing through the second-dimension column. Previous method development experiments (data not shown) confirmed this to be an appropriate composition for adequate retention of Irbesartan and its related compounds.

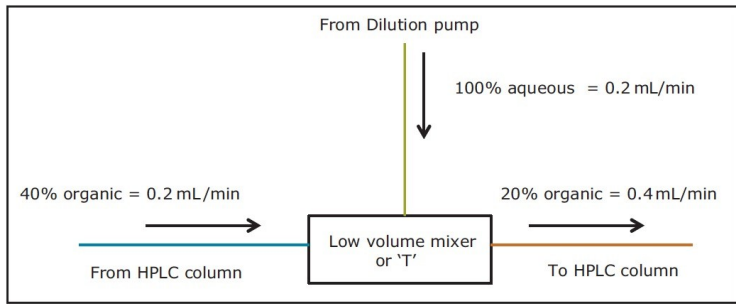

Figure 5. Principle of Waters at-column dilution applied to this peak transfer.

---

## Results and Discussion

### Peak transfer

The USP assay for Irbesartan was run, with UV detection, as a single-dimension method on the ACQUITY UPLC System with 2D-LC Technology. The UV chromatogram obtained with this method can be seen in Figure 6. The expected Irbesartan API peak (retention time 15.30 min) is present, but a small, unidentified peak (12.70 min) is also observed. This separation exemplifies the two circumstances mentioned previously. The Irbesartan API peak will be transferred for the purposes of confirmation as would be required in the context of a validation. Being an unexpected peak, the unknown at 12.70 minutes will be transferred and mass spectral data collected to begin characterization.

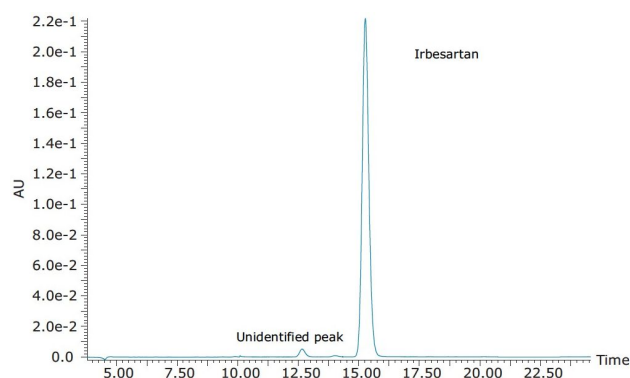

*Figure 6. UV chromatogram of the USP assay for Irbesartan.*

The USP method was run on the ACQUITY UPLC System with 2D-LC Technology configured for peak transfer (heart-cut). The valve event settings were adjusted to transfer a portion of the large API peak. After the USP mobile phase is flushed from the UPLC column, an organic gradient of acetonitrile was used to elute the analyte to the ACQUITY QDa Detector. The SIR results confirmed the identity of the API as Irbesartan  $m/z$  429.2 (Figure 7). The protocol was repeated for the small, unidentified peak at 12.70 minutes. A common impurity in the formulation is Irbesartan related compound A (RC-A). A selective ion channel for this specific mass was screened. Subsequent elution of this unknown peak to the mass spectral detector confirmed the analyte as Irbesartan RC-A by SIR at  $m/z$  447.1 (Figure 8).

In each transfer, the USP UV method was run unaltered. The transfer window for the peak transfer, determined from the time settings for the valve events, was adjusted to divert either part or all of the volume of the selected peaks. For a large, concentrated peak such as the API, only a small portion is required to be transferred and eluted to the mass spectral detector for mass assignment. For

smaller peaks, such as RC-A, it was desirable to transfer the entire volume of the chromatographic peak to ensure the best possible spectral data. This would be a necessity for quantification.

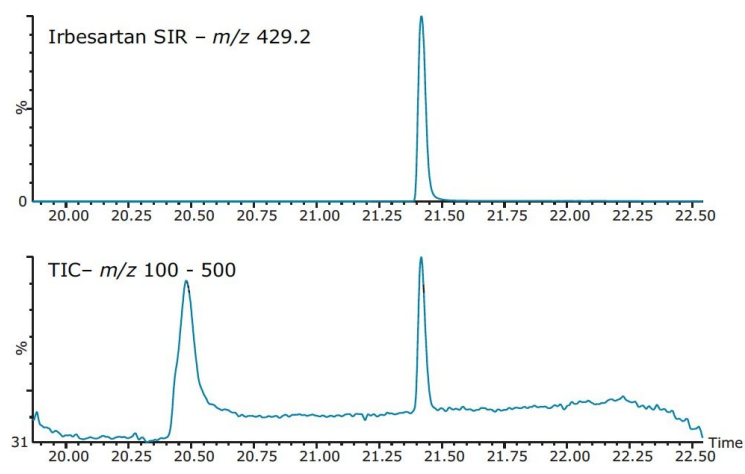

Figure 7. Confirmation of the Irbesartan API peak.

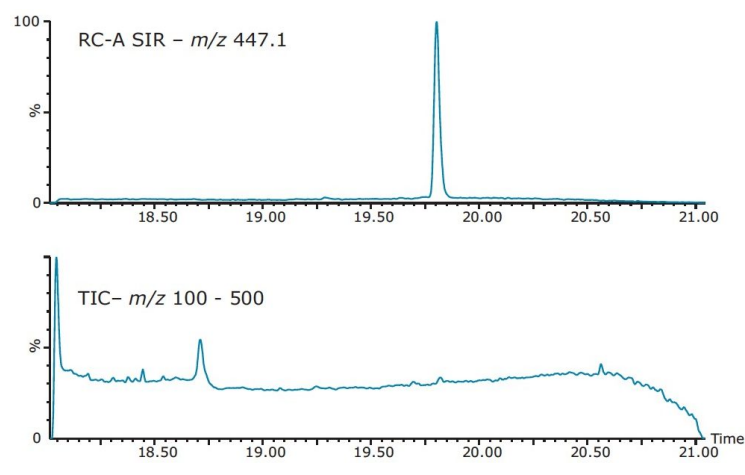

Figure 8. Confirmation of the unexpected peak as Irbesartan RC-A by SIR.

## Repeatability

To assess the repeatability of the peak transfer, five consecutive injections were performed. There was no variation in the second-dimension elution time of the transferred RC-A peak. Area repeatability for the five injections had a %RSD of 4.2 (Figure 9), indicating the automated peak transfer process was highly repeatable.

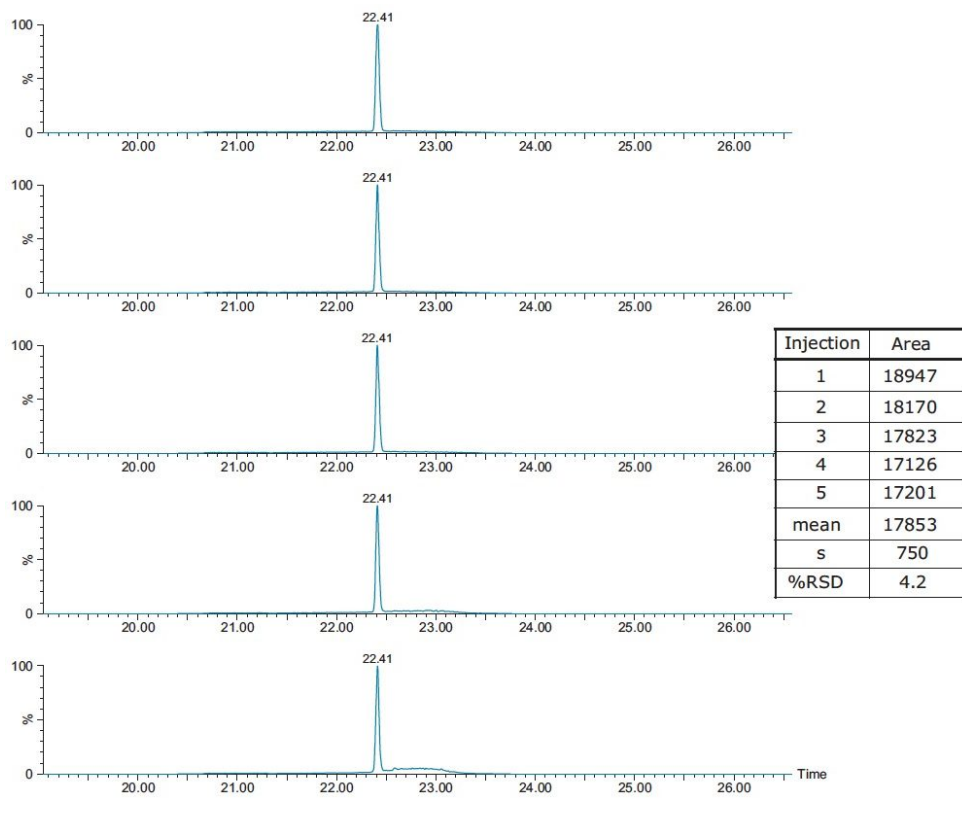
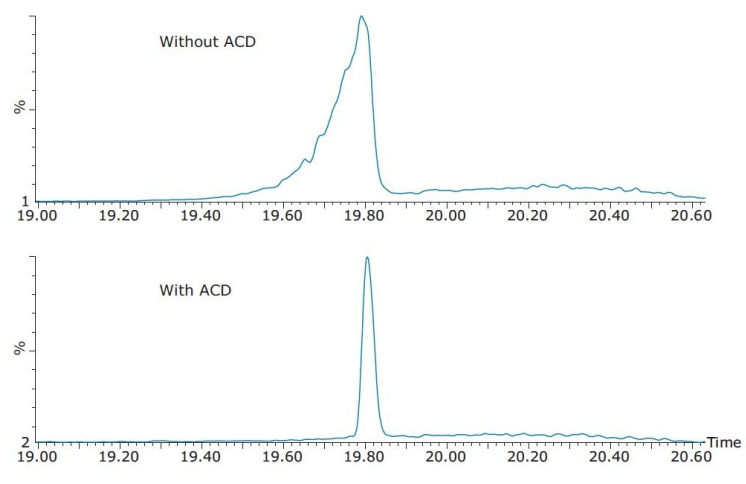

Figure 9. Repeatability of the automated protocol.

### At-column dilution

The use of at-column dilution in this protocol was critical to the quality of the chromatographic results. Figure 10 compares the gradient eluted RC-A peak observed with and without ACD. With the dilution pump off (no ACD), the Beta pump elutes the transferred peak volume to the UPLC column using the USP mobile phase containing 40% acetonitrile. Upon final gradient elution, the RC-A peak is asymmetric, fronting strongly. The organic composition of the undiluted mobile phase was too high for good retention on the second dimension. With the dilution pump flowing (ACD) and the flow rate matching that of the Beta pump during the peak transfer, the organic composition of the mobile phase was reduced by half to 20% acetonitrile. The lower percent of organic improved the retention of RC-A on the second-dimension column, exemplified by the symmetrical RC-A peak. It is important to note that RC-A is a moderately hydrophobic analyte. A more hydrophilic compound would have displayed more severe peak distortions (splitting, retention shifts).



*Figure 10. Waters at-column dilution improves the quality of the chromatographic result.*

---

## Conclusion

Mass spectral detection of peaks from USP analyses can be problematic due to the high ionic strength, non-volatile mobile phases often used with these methods. When MS is needed, the choices have been fraction collection and solvent exchange prior to a reanalysis, or the development of a separate method using a volatile mobile phase. Both choices incur penalties in time and cost.

The ACQUITY UPLC System with 2D-LC Technology system configured for peak transfer can directly transfer a selected peak from a USP chromatographic method to the ACQUITY QDa Mass Detector for mass spectral analysis with no fraction collection, and no redevelopment of the USP method. Configuring the system for at-column dilution will further ensure the quality and repeatability of the mass spectral data collected from the transferred peak.



---

## References

1. USP Monograph Irbesartan, USP37-NF32, 3396. The United States Pharmacopeial Convention, official from August 1, 2014.

---

## Featured Products

[ACQUITY UPLC Systems with 2D LC Technology](#)

[ACQUITY QDa Mass Detector](#)

[MassLynx MS Software](#)

[ACQUITY UPLC PDA Detector](#)

720005306, February 2015